

DC-DC

DCC1212 -20 | 40 | 60

DCC1224 -10 | 20 | 30

2023.02

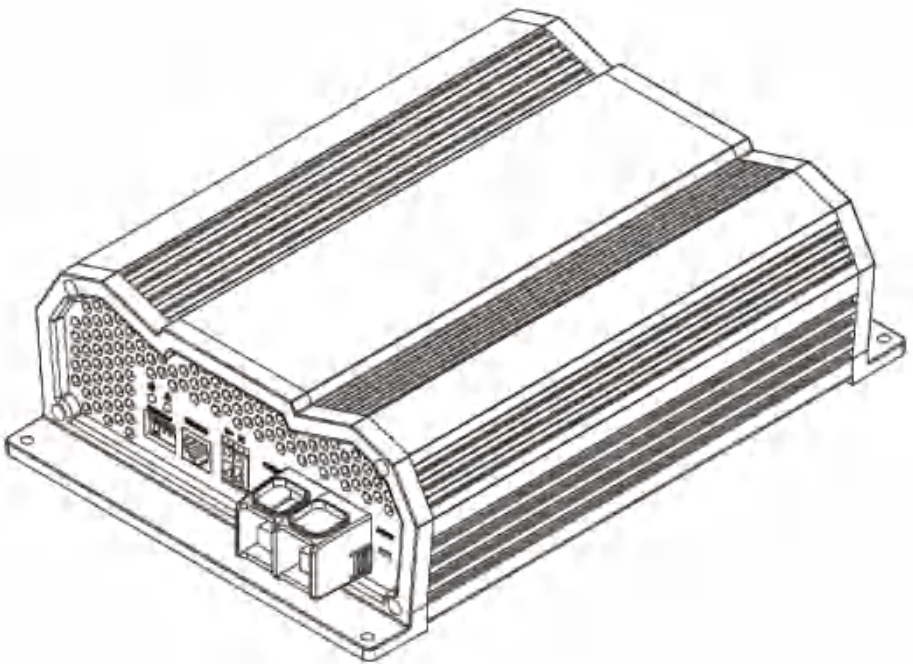

Important Safety Instructions

Please save these instructions.

This manual contains important safety, installation, and operating instructions for the charger. The following symbols are used throughout the manual to indicate potentially dangerous conditions or important notes.

WARNING

Indicates a potentially dangerous condition. Use extreme caution when performing this task.

CAUTION

Indicates a critical procedure for the safe and proper installation and operation of the controller.

NOTE

Indicates a procedure or function that is important to the safe and proper operation of the controller.

The manufacturer accepts no liability for damage by:

- Faulty assembly or connection
- Damage resulting from mechanical influences or excess voltage
- Modification or tampering with the unit without expressed permission from the manufacturer
- Used for purposes other than described in this manual

General safety

WARNING

Risk of electric shock, fire hazard, or injury. To minimize risk:

- Ensure the positive and negative terminals for the charger do not come into contact
- Firmly secure cables and connections.
- Disconnect the product from the battery each time before cleaning or before making changes to the circuit.
- Do not use the product if physically damaged or with visibly cracked cables. Contact the manufacturer, customer service to prevent safety hazards
- Do not attempt to repair the charger. Inadequate repairs may cause serious injury
- Electrical devices are not toys—keep away from children.

Installation Safety

- This charger is for 12V battery banks only. make sure your voltage specification is within the input voltage range expressed.
- Install and store the product in a dry and cool place. Keep away from liquids! Do not expose the product to heat sources such as direct sunlight or other heating elements.
- Never mount in areas with increased levels of dust or gas—explosion risk!

-
- Ensure secure location where it cannot tip or fall
 - For installation on boats: if the electrical devices are incorrectly connected, this can lead to corrosion damage on the boat. Verify installation with a qualified electrician or installer
 - Lay cables so they cannot be damaged by doors or be a tripping hazard. Damaged cables can lead to serious injury
 - Use ductwork or cable ducts if necessary, to lay cables through metal plates or other panels
 - Do not lay AC and DC cable in the same conduit and do not pull on the cables.

Operation Safety

- Warning—Explosion Risk! Batteries can give off explosive hydrogen gas that can be ignited by sparks or electrical connections. Make sure the area is well-ventilated.
- Do not operate in salty, wet, or damp environments; in the vicinity of corrosive fumes; in the vicinity of combustible material; in areas with risks of explosions
- Please be aware that parts of this product may still produce voltage even after disconnected or activation of fuse.
- Do not disconnect cables while the product is operating

Battery Safety

- Warning—Explosion Risk! Batteries may contain corrosive acids or fumes. Avoid contact with battery acid. If your skin comes into contact, thoroughly wash the affected area with water. Any other injuries should seek medical care.
- Avoid wearing metal objects such as watches or rings when working with batteries. Short circuit risk!
- Use only rechargeable deep cycle batteries. NEVER attempt to charge a frozen or defective battery.
- Wear goggles, gloves, or other protective clothing when working with batteries. Do not touch your eyes.
- Ensure proper cable sizing for batteries! Over-current protection devices should be on the positive line.
- Refer to your battery manufacturer for battery maintenance and care
- When removing a battery, power off all loads first, then disconnect it from the circuit before removing.

Table of Contents

Safety Information	01
General Information	04
Product Overview	05
Identification of Parts	05
Dimensions	06
Optional Components	07
Installation	07
Location Considerations	07
Wiring and Fusing	09
Grounding	09
DC Output Wiring (House)	10
DC Input Wiring (Starter)	11
D+ Ignition Wiring	12
LC Current Limit Wiring	14
Operation	15
LED Indicators	15
Setting Battery Type	15
Setting Lead Acid	16
Setting Lithium	17
Battery Charging Logic	18
Lithium Activation	18
Troubleshooting	19
Maintenance	21
Technical Specifications	22
Temperature Compensation	22

General Information

The DC-DC Series battery chargers are the most effective way to charge your auxiliary or house batteries from the alternator/starter battery. Compatible with smart or traditional alternator types, the DC-DC offers correct charging for AGM, Flooded, Gel, and even Lithium deep cycle batteries! Featuring a 3-stage battery charger and multiple electronic protections, owners can feel confident that their batteries are being charged optimally and automatically. Easily install the compact yet sturdy DC-DC on RV's, commercial vehicles, boats, yachts and many more applications.

Key Features

-
- Smart protections features including Over-voltage, Over-Temperature, and reverse polarity!
- Battery Isolation and Battery Charger in one
- Compact yet built tough for all conditions
- 3-Stage Battery Charger get your batteries to 100%

Check the charging requirements from the battery manufacturer before charging your battery with this unit.

Product Overview

Identification of Parts

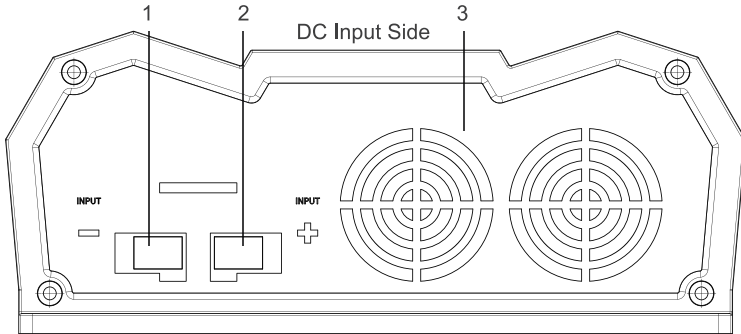

Key Features

1. Negative DC Input Terminal
2. Positive DC Input Terminal
3. Ventilation Fans

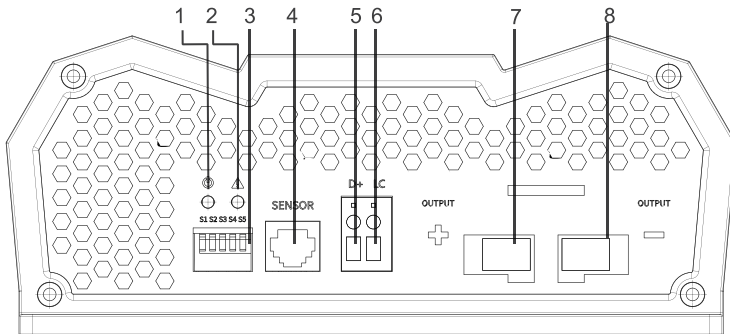

DC Output Side

Key Features

- | | |
|--|---|
| <ol style="list-style-type: none"> 1. Power LED 2. Fault LED 3. Dip Switches 4. RJ11 Temperature Sensor Port (Model: RTSDCC, requires separate purchase) | <ol style="list-style-type: none"> 5. D+ Ignition Terminal 6. LC Terminal – Current Limiting Terminal 7. Positive DC Output Terminal 8. Negative DC Output Terminal |
|--|---|

Dimensions

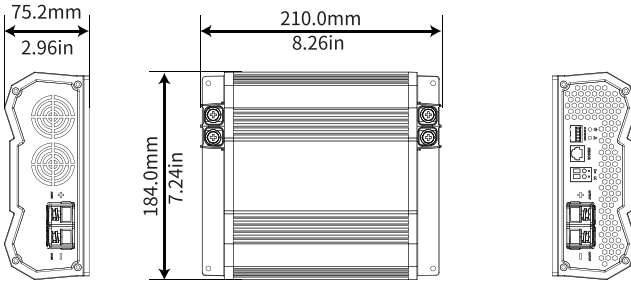

DCC1212-20/1224-10

NOTE

The dimensions have a $\pm 0.5\text{mm}$ tolerance

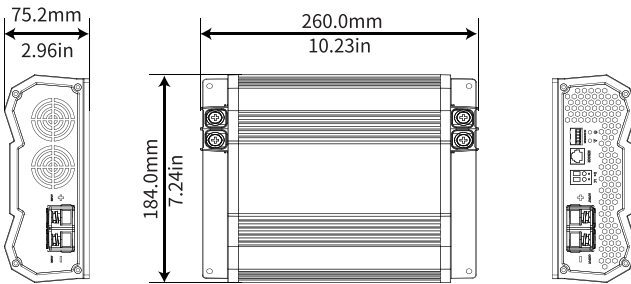

DCC1212-40/1224-20

NOTE

The dimensions have a $\pm 0.5\text{mm}$ tolerance

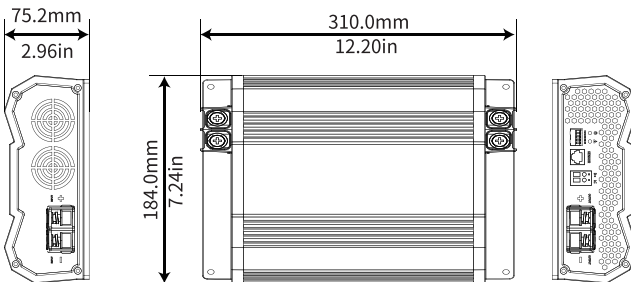

DCC1212-60/1224-30

NOTE

The dimensions have a $\pm 0.5\text{mm}$ tolerance

Optional Components

DC-DC Temperature Sensor (Model: RTSDCC)

CAUTION Do not use with Lithium batteries.



The RTSDCC comes in handy for reading incoming temperature values from the house battery bank while adjusting the charging voltage of your DC to DC On-Board Battery Charger. Featuring a temperature operation range from $-4^{\circ}\text{F} \sim 176^{\circ}\text{F}$ / $-20^{\circ}\text{C} \sim +80^{\circ}\text{C}$, the sensor will be important in the overall lifespan and performance of your house battery bank by applying higher charging voltage to counter the increased resistance due to low temperature. Simply connect the RTSDCC to the charger and place the sensor on top or on the side of the house battery bank and the charger will take care of the rest with temperature compensation.

Installation

DANGER

CAUTION Cannot tip over or fall down.

NOTICE Avoid additional heating of the product.

Location Considerations

For installations in small, enclosed spaces. The minimum clearance around the battery charger must be at least 5cm.

When selecting a location for the DC-DC, make sure that the unit is as close as possible to the battery you will be charging (auxiliary battery). The charger may be mounted on the cabin of the vehicle, along a chassis rail, the inner guard of a vehicle, behind the grille or headlight or even on the side of the radiator. However, you want to make sure that the area is not susceptible to moisture or other substances as well as potentially high temperatures.

The DC-DC would operate best if there is some air flow.

■ Mounting

- Have at least 5cm of clearance from all areas and ensure some ventilation for best performance
- Trace the mounting holes with a pencil/pen when placing the DC-DC against the desired area
- Use 4 x screws to secure the dc-dc onto a surface

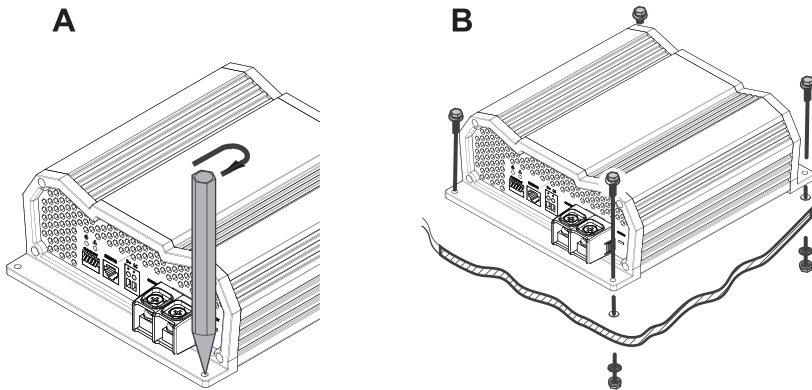
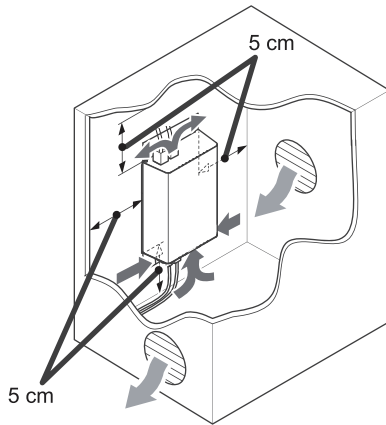

Wiring and Fusing

Battery Ring terminals are recommended for 12V input and 12V/24V output connections. The following is a reference incorporating a critical 0-3% max voltage drop and may not cover all unique applications that may exist. When the battery charger is sending the rated amps, the input side may experience a draw higher current draw by a factor of up to 50%. Larger wire sizes generally improve performance, whereas smaller wire sizes may reduce performance, especially if undersized. When considering wiring, fusing, and connection options, think big and short as possible as heavier components and shorter wire length offer less resistance and voltage drop. Terminal Size Limitations may apply. The installer is responsible for ensuring that the correct cable and fuse sizes are used when installing the DC-DC battery charger.

Model	Cable	Cable Length/ Min AWG			Recommended Fuse
		0 ~ 10ft / 0 ~ 3m	11 ~ 20ft / 3 ~ 6m	21 ~ 30ft / 6 ~ 9m	
DCC1212-20 /1224-10	To DC Input (Starter)	10AWG	8-6AWG	6-4AWG	30A or close
	To DC Output (House)	12AWG	10-8AWG	6AWG	25A or close
DCC1212-40 /1224-20	To DC Input (Starter)	6AWG	4AWG	4AWG*	60A or close
	To DC Output (House)	8AWG	8-6AWG	4AWG	50A or close
DCC1212-60 /1224-30	To DC Input (Starter)	4AWG	4AWG*	4AWG*	90A or close
	To DC Output (House)	6AWG	4AWG	4AWG*	75A or close

*3-10% Non-Critical Voltage Drop

■ Grounding

NOTE

Depending on the application, the grounding point may differ.

The DC-DC share a common negative ground meaning that there should be only one common ground point between all batteries and electronics typically seen in either chassis/body ground, a canopy, a trailer, or even the vehicle battery negative connection. In most cases, connecting the starter and house battery directly to the DC-DC is enough for a grounding application. You will not ground the body of the DC-DC. In the illustration below, the two batteries are connected to the same chassis ground point.

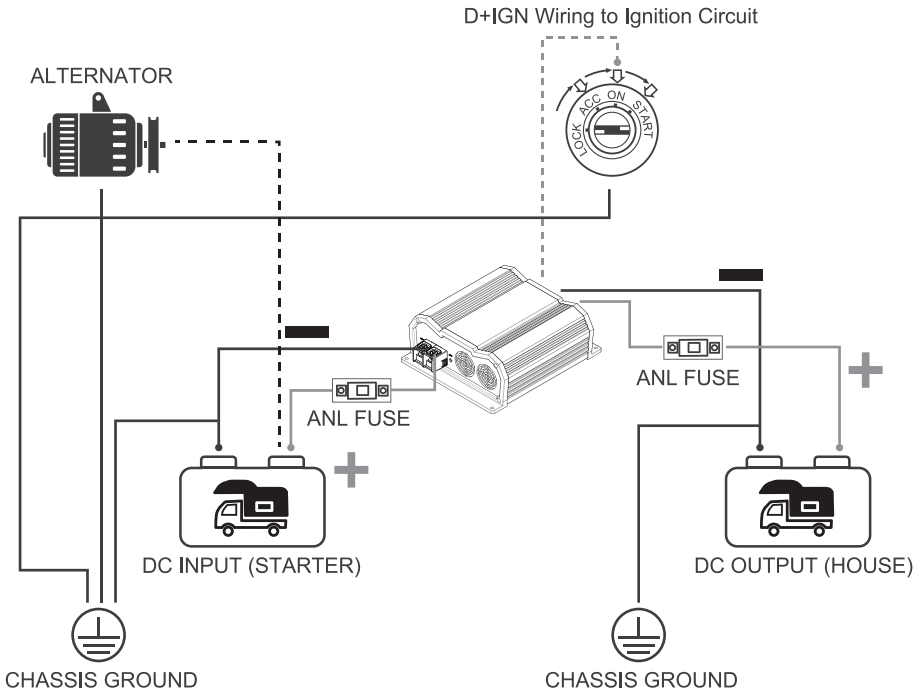

DC Output Wiring (House)

WARNING

Only use 12V/24V batteries. Damages due to connecting higher voltage batteries will not be covered in warranty.

The DC-DC output will connect to the 12V/24V auxiliary or house battery that you are intending to charge. These batteries may be a different chemistry from the starter battery. The DC-DC input and output terminals are isolated, meaning that the output voltage can be kept stable without interference from the input circuit. This ensures stable and correct charging of auxiliary batteries. It is best to place the DC-DC closer to the battery you will be charging primarily.

1. Use a screwdriver to loosen the DC output terminals by rotating counterclockwise (CCW)
2. Connect a ring terminal cable from House Battery Positive to the Positive DC Output Terminal
3. Use a screwdriver to tighten the DC output terminal by rotating clockwise (CW)
4. Repeat for the House Battery Negative to the Negative DC Output Terminal

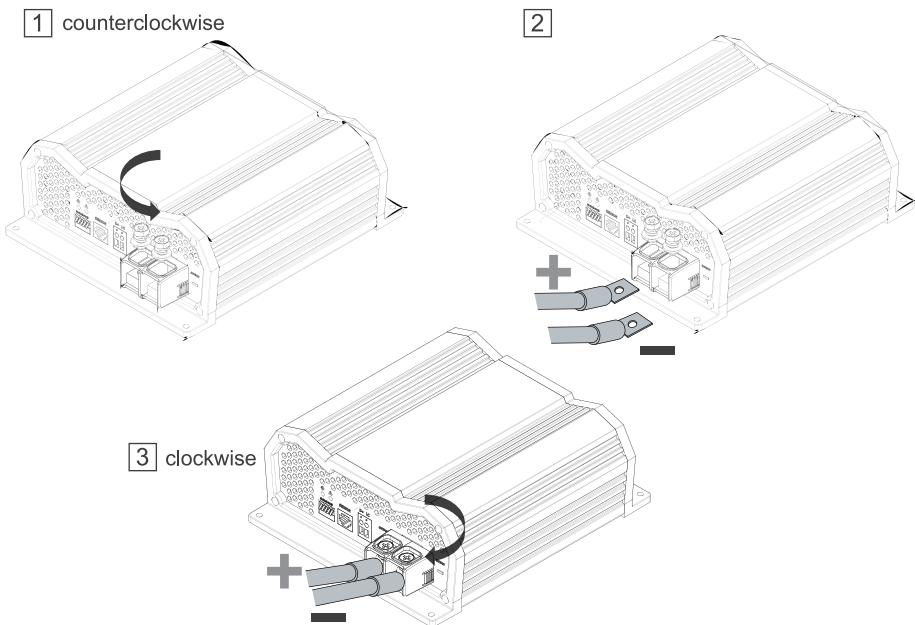

■ DC Input Wiring (Starter)

The DC-DC will not power on or operate until the D+ ignition cable is connected. When connecting the DC input, note that the DC-DC will still be off until the D+ ignition cable voltage senses.

The DC-DC input will connect to the 12V starter battery that will be used to charge your auxiliary or house battery. The starter battery may be a different chemistry from the house battery. The DC-DC input and output terminals are isolated, meaning that the output voltage can be kept stable without interference from the input circuit. This ensures stable and correct charging of auxiliary batteries.

1. Use a screwdriver to loosen the DC input terminals by rotating counterclockwise (CCW)
2. Connect a ring terminal cable from Starter Battery Positive to the Positive DC Input Terminal
3. Use a screwdriver to tighten the DC Input terminal by rotating clockwise (CW)
4. Repeat for the Starter Battery Negative to the Negative DC Input Terminal

1 counterclockwise

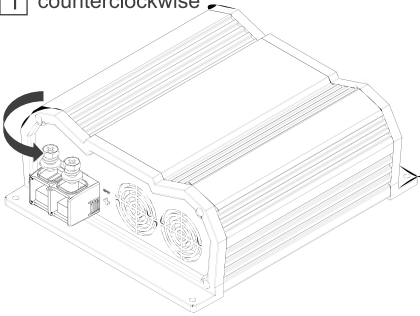

2

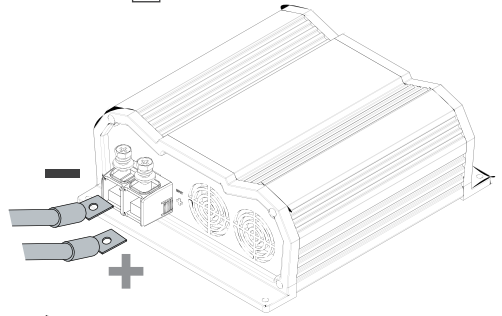

3 clockwise

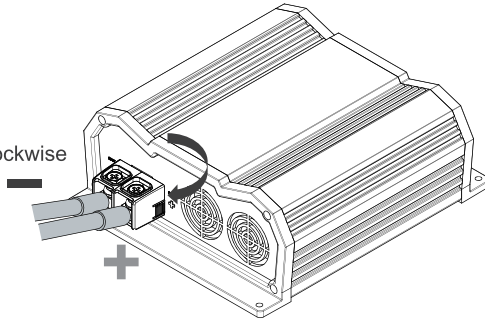

D+ Ignition Wiring

The D+ terminal will be located on the output side but connects to the DC ignition circuit of the input starter battery. This may be in the engine bay fuse block for some vehicles. Refer to your own vehicle's electrical diagram for D+ wiring placement.

May require splicing or cable adjustments to connect correctly to your ignition circuit.

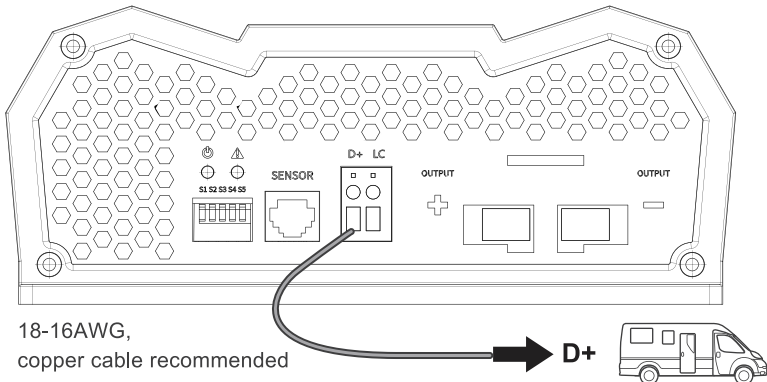

The DC-DC will not power on or operate until the D+ ignition cable is connected to the ignition circuit where it will detect a 12V source to operate ON. The purpose is to toggle the DC-DC switch on when the vehicle is running with the alternator to prevent the DC-DC from operating incorrectly with just the starter battery leaving you with a drained starter battery. Use 18-16AWG copper cable. You may need a multi-meter to test your connections to verify placement of the D+ wire.

Alternator Recommendation

Check your alternator and identify the number of terminals. Most alternators will have 3 wires connected (BATT+, BATT-, IGN). The following is an example and may not match your application. Refer to your vehicle's documentation and part for actual wiring

1	BATT+	Could be labeled as "B", "Bat", or "Pos". This will connect directly to the battery and typically be heavy gauge for high current applications.
2	BATT-	Could be labeled as "Neg", "Field" or "F". This will connect to ground. Some alternators may not have this as they will be directly grounded to the engine.
3	IGN	Could be labeled "IGN" or "L" and will likely be the smaller terminal. This connects to the ignition circuit or dashboard warnings signs. This is where you will want to splice the D+ ignition cable.

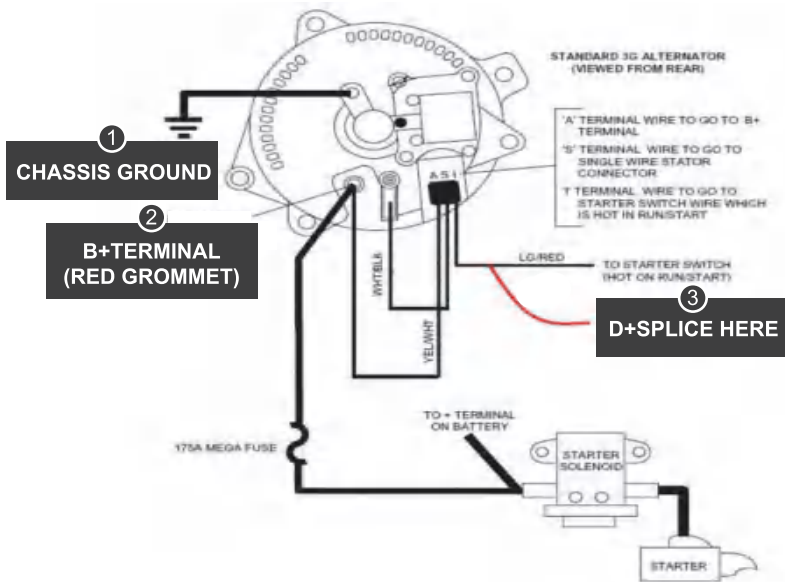

Engine Bay Fuse Block Recommendation

Review your vehicle's fuse layout diagram to identify a fuse location that is live when the vehicle is running with the alternator. Key positions in the ignition are typically lock, accessory, on, and start.

LOCK	Off position where no accessories will work, and steering is also likely locked
ACCESSORY	Accessories are given power such as radio and some other small electronics.
ON	Turns on all your electronics. The key will default into this position after cranking in START. Splicing of fuse block will need to be live when the key is in reverting back to this position
START	Cranks the engine on and reverts to ON position.

You may need to test the fuse location by checking the voltage with a multi-meter and making sure it's live only when the vehicle is in the Start/Run position. This will help in identifying where to connect if the fuse layout does not have an IGN position. The easiest connections when splicing can be made when using a fuse holder splice connector.

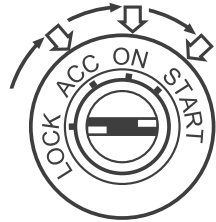

LC Current Limit Wiring

The DC-DC battery chargers feature 50% current limiting from the rated specification when connecting the LC Terminal to a 12V source. Current Limiting is instant and recommended to be connected to the same location as the D+ ignition cable. Alternatively, you can toggle current limiting to your liking by connecting the LC terminal to starter battery positive terminal. In this fashion, current limiting will always take until removing the LC wire from the battery terminal to revert to the normal amp rating. Use 18-16AWG copper cable for the LC terminal and you may need to splice your own connections for the other cable end depending on your connection point.

Model	Amp Rating	Current Limit
DCC1212-20	20A	10A
DCC1212-40	40A	20A
DCC1212-60	60A	30A
DCC1224-10	10A	5A
DCC1224-20	20A	10A
DCC1224-30	30A	15A

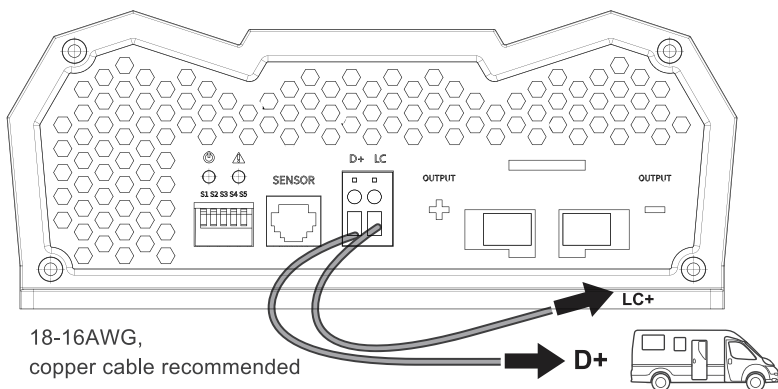

Operation

Assuming correct 12V/24V battery connections and D+ ignition cable wiring, then the POWER LED will illuminate green.

LED Indicator

Power LED

Color	Status	Meaning
Green	Off	Powered Off; if abnormal refer to troubleshooting
	Solid ON	Normal

Color	Status	Meaning
Red	Off	No faults
	Solid ON	Fault detected; refer to troubleshooting

Setting Battery Type

WARNING

Refer to your battery manufacturer specifications when selecting a battery type via Dip switches. Damage due to incorrect battery settings will not be covered in warranty.

DIP Switches

The 5 x dip switches can be configured to charge lead acid or lithium batteries. Note that ON is position down and OFF is position up if facing the dip switches directly. Lead acid profiles have an absorption charge and a float charge whereas lithium batteries will only have an absorption charge and no float charge.

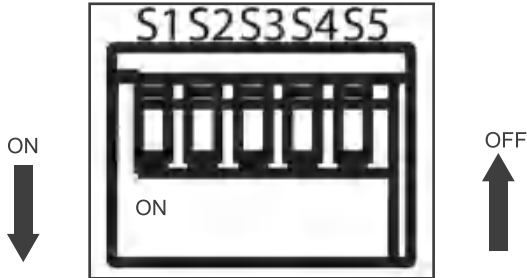

Setting Lead Acid

Lead acid assumes deep cycle AGM, Gel, Flooded, and Sealed Lead Acid. To get started, make sure SW5 = ON to gear the charger for lead acid batteries. Next select your absorption charge and float charge below by configuring the dip switches to your desired specifications.

DIP Switch	Meaning
SW1, SW2	Set Absorption Charge Voltage
SW3, SW4	Set Float Charge Voltage
SW5	ON—Lead Acid

Set Absorption Charge			
SW1	SW2	Voltage	
		DCC1212	DCC1224
ON	ON	14.4	28.8V
OFF	ON	14.1	28.2V
ON	OFF	14.7	29.4V
OFF	OFF		

Set Float Charge			
SW3	SW4	Voltage	
		DCC1212	DCC1224
ON	ON	13.8 V	27.6V
OFF	ON	13.5 V	27.0V
ON	OFF	13.2V	26.4V

Setting Lithium

To get started, make sure **SW5 = OFF** to gear the charger for lithium batteries. There will not be a float voltage and instead users will select between Type 1 lithium voltages or switch into Type 2 lithium voltages depending on your lithium battery specifications. You must select a lithium Type to when selecting your charge voltage. Type 1 voltages range from 12.6V ~ 13.0V (25.2V~26.0V) and Type 2 voltages range from 14.0V~14.6V(28.0V~29.2V).

DIP Switch		DIP Switch		Lithium Voltage	
SW5=OFF	SW1	SW3	SW4	DCC1212	DCC1224
		OFF	ON	13.0V	26.0V
	SW2	OFF	ON	12.8 V	25.6V
		OFF	OFF	12.6V	25.2V
	DIP Switch		Lithium Voltage		
	SW3	SW1	SW2	DCC1212	DCC1224
		ON	ON	14.6 V	29.2V
	SW4	ON	OFF	14.2V	28.4V
		OFF	OFF	14.0V	28.0V

Battery Charging Logic

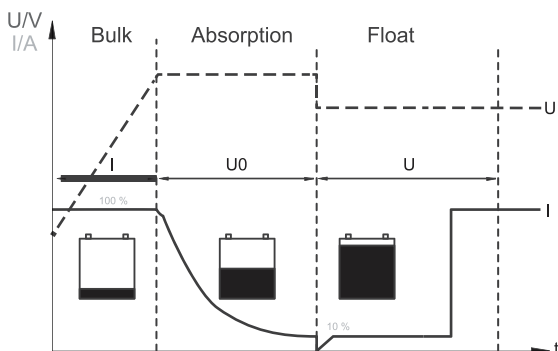

Bulk (Phase I) (Lead Acid + Lithium)

In the beginning, a discharged battery will be charged with maximum current and voltage will be climbing steadily until reaching the absorption voltage setpoint.

Absorption (Phase U0) (Lead Acid + Lithium)

The battery reaches the absorption voltage setpoint and holds the voltage constant while the current gradually decreases until the battery is becoming full (within 10-20%). By default, absorption will not exceed 3 hours to prevent overcharging.

Float (Phase U) (Only Lead Acid)

After the absorption stage, the voltage of the battery will reduce to the float voltage setpoint and current will also reduce to a low maintenance mode to prevent the battery from discharging and offsetting any self-discharge. Heavier battery discharge may set controller back to Bulk/Absorption to replenish energy lost while energy is available.

Lithium Activation

NOTE

This is an automatic process for Lithium batteries. Ensure correct lithium polarity when connecting to the DC Output.

The DC-DC have reactivation feature to awaken a sleeping lithium battery. The protection circuit of Lithium batteries will typically turn the battery off and make it unusable if over-discharged. This can happen when storing a Lithium pack in a discharged state for any length of time as self-discharge would gradually deplete the remaining charge. Without the wake-up feature to reactivate and recharge batteries, these batteries would become unusable and the packs would be discarded. A small charge current will be applied to the house battery to activate the protection circuit and if a correct cell voltage can be reached, it starts a normal charge.

Troubleshooting

If the DC-DC is not functioning correctly, it may be undergoing an internal electronic protection and stop normal operation. This is not indicative of a defective unit but may require some troubleshooting to resume normal operation.

Electronic Protection

Behavior	Protection	Troubleshoot Steps				
Red Fault LED ON	Battery Overvoltage	<p>1. Use a multi-meter to measure the DC input and DC output batteries as well as the respective DC-DC input/output terminals. Battery over-voltage is 15.5-16V:</p> <table border="1"> <tr> <td>High Voltage Shutdown</td> <td>16V</td> </tr> <tr> <td>High Voltage Restart</td> <td>15.5V</td> </tr> </table> <p>2. Disconnect any other chargers in the circuit and let the battery rest to lower the voltage. Disconnect any sensitive loads.</p> <p>3. Double check correct DIP switches</p>	High Voltage Shutdown	16V	High Voltage Restart	15.5V
	High Voltage Shutdown	16V				
	High Voltage Restart	15.5V				
Battery Undervoltage	<p>1. Use a multi-meter to measure the DC input and DC output batteries as well as the respective DC-DC input/output terminals. They should be similar. Battery undervoltage is below 8-10V.</p> <table border="1"> <tr> <td>Low Voltage Cut-out</td> <td>8V (Lead Acid)</td> </tr> <tr> <td>Low Voltage Restart</td> <td>10V</td> </tr> </table> <p>2. Disconnect any other loads in the circuit and let the battery charge.</p> <p>3. Lead acid batteries below 8V may need an external charger to reach minimum DC-DC voltages; Lithium batteries will be able to recover due to Lithium Activation.</p>	Low Voltage Cut-out	8V (Lead Acid)	Low Voltage Restart	10V	
Low Voltage Cut-out	8V (Lead Acid)					
Low Voltage Restart	10V					
Reverse Polarity	<p>1. Use a multi-meter in DC Volts and probe the positive line onto the positive battery terminal and probe the negative line to the negative battery terminal. You should see a reading within 10V~14V and be a positive number.</p> <p>2. If the DC reading is negative, your poles are reversed. Fix the wiring to return to normal operation.</p> <p>WARNING Lithium batteries in reverse polarity may cause irreversible damage to the dc-dc.</p>					

Behavior	Protection	Troubleshoot Steps
Red Fault LED ON	High Temperature	<p>1. Double check that your wiring is correct with a multi-meter and that the battery levels are suitable within the operating voltage range</p> <p>2. Observe the ambient temperature. Avoid installations in direct sun. Ambient temperatures above 122°F/50°C will cause the unit to stop functioning until conditions get cooler.</p> <p>Move the unit to a cooler location or introduce ventilation into the install location. The protection is automatic, and the dc-dc will resume normal function upon cooling down.</p>
	Short Circuit	<p>1. The DC-DC is experiencing an internal short circuit due to an imbalance between its input and output circuits. Restart the DC-DC by disconnecting the input/output and then reconnecting it again.</p> <p>The error will clear automatically upon a successful restart. If issues continue with a permanent red led, then contact support to address the previous troubleshooting steps.</p>

More Troubleshooting

Behavior	Cause	Fix
Green Power LED OFF, batteries correctly connect-	Incorrect D+ Connection	<p>1. Check to make sure there is a cable connected between the D+ Terminal (DC Output Side) and the ignition circuit. The D+ needs a 12V signal to start/stop the DC-DC. Splicing required. Refer to your vehicles fuse box layout to identify the ignition line or similar location that is live when the alternator is running.</p>
	Wrong battery at input/output	<p>1. Verify correct battery placement with tight and secure connections, eliminate any breaks.</p> <p>2. DC Input terminals should be the starting battery and should also have a charging source (alternator in this case).</p> <p>3. DC output terminals should be the auxiliary or house battery you're charging.</p>
	Battery voltage too low or high	<p>1. The DC-DC requires 12V batteries more than 10V (Lead Acid) and can not exceed 15.5V so no 24V batteries.</p> <p>Use a multi-meter to measure the battery terminals and verify that the dc-dc terminals match the respective values (or similar).</p> <p>Continued problems with batteries may need to be taken to a nearby battery tester at your nearby automotive shop.</p>

Behavior	Cause	Fix
	Connection break	<ol style="list-style-type: none"> 1. Inspect your connections for tight, secure, and undamaged wiring to and from the DC-DC 2. Check fuses for any breaks and replace them to continue normal operation. 3. Use your multi-meter's (check with manufacturer) continuity test to individually check each line (positive and negative) at the input and output to verify consistent connection. Audible multi-meter Beeps indicate continuity. No sound indicates connection break.

Maintenance

For best DC-DC performance, periodically check the unit and related wiring monthly as well as the installation location:

1. Inspect the wiring and note any wiring cracks, wear, tear, corrosion, or loose wiring and replace immediately. Inspect wiring terminals and ensure they're tight as they may become loose during vehicle vibrations.

2. Check that the battery charger is free of dust, liquids, or heat sources and ensure the DC-DC is receiving some ventilation. Improved ventilation improves performance.

Technical Specifications

Model	DCC1212-20/ 1224-10	DCC1212-40/ 1224-20	DCC1212-60/ 1224-30
Transformation	12V → 12V(DCC1212) 12V → 24V(DCC1224)		
Input Battery Voltage Range	8V ~ 16VDC		
Rated Charging Current	20A/10A	40A/20A	60A/30A
Charging Voltage Range	Lead Acid:13.2V~14.7V;Lithium:12.6V~14.6V(DCC1212) Lead Acid:26.4V~29.4V;Lithium:25.2V~29.2V(DCC1224)		
Rated Max Power	250W	500W	750W
Residual ripple of output voltage at rated current	< 50 mV		
Efficiency	90 %		
Idle power consumption	0.4 A		
Operational temperature (Ambient)	-4 °F ~ 122 °F/ -20 °C to +50 °C		
Temperature Compensation	-3mV/C° /2V		
Humidity			
Dimensions	211 x 175 x 68 mm	261 x 175 x 68 mm	311 x 175 x 68 mm
Weight	3 lbs. / 1.3 kg	4 lbs. / 1.9 kg	5.3 lbs. / 2.4 kg
Terminal Size	M6 x 10mm		
Terminal Torque	2.2 - 2.6 lbf - in /24.5 - 29.4 N - cm		
Certification	CE		

Temperature Compensation

NOTE

The temperature compensation is not to be used with lithium batteries.

