

# 3-EV-180(B)

(6V180Ah/5HR)



3-EV-180(B) is a flooded Lead Acid battery that adopts Tubular Plate technology to offer high reliability and performance. It is specially designed for frequent deep cycle discharge. The Battery is designed and manufactured according to GB/T 32620-2016 standards and with die-casting positive spine and patent formula of active material. Suitable for mobility scooters, electric wheel chairs, golf buggies etc.

## Specification

<b>Voltage Per Unit</b>	6V
<b>Capacity</b>	230Ah@20hr-rate to 1.60V per cell @25°C 180Ah@5hr-rate to 1.70V per cell @25°C
<b>Approx Weight</b>	Including electrolyte 29.0 Kg
<b>Internal Resistance</b>	Approx. 3.0mΩ
<b>Operating Temperature Range</b>	Discharge:-40°C~60°C Charge:-20°C~50°C Storage:-40°C~60°C
<b>Optimal Operating Temperature Range</b>	25°C±5°C
<b>Float charging Voltage</b>	6.9 to 7.2 VDC/unit Average at 25°C
<b>Maximum Charging Current</b>	36A
<b>Cycle Service</b>	7.95 to 8.55 VDC/unit Average at 25°C
<b>Self Discharge</b>	Self-discharge rate less than 3.5% per month at 25°C. Please charge batteries before using.
<b>Container Material</b>	PP



## Dimensions

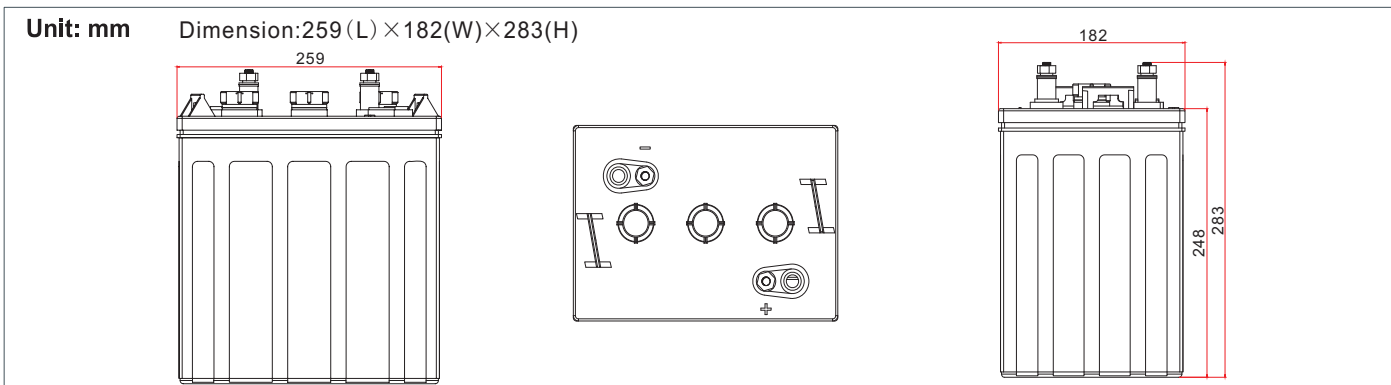

Constant Current Discharge Characteristics: A(25°C)										
F.V/Time	30MIN	1HR	2HR	3HR	4HR	5HR	6HR	8HR	10HR	20HR
4.80V	170.5	119.4	69.2	51.8	42.3	37.9	32.9	25.6	21.1	11.7
4.95V	166.6	116.7	67.6	50.6	41.3	37.0	32.1	25.0	20.6	11.3
5.10V	161.9	113.4	65.7	49.2	40.1	36.0	31.2	24.3	20.1	10.9
5.25V	155.8	109.0	63.2	47.3	38.6	34.6	30.0	23.4	19.3	10.4
5.40V	148.7	104.1	60.3	45.2	36.9	33.1	28.7	22.3	18.4	9.9
5.55V	140.9	98.7	57.2	42.8	34.9	31.3	27.2	21.1	17.5	9.1

Constant Power Discharge Characteristics: W(25°C)										
F.V/Time	30MIN	1HR	2HR	3HR	4HR	5HR	6HR	8HR	10HR	20HR
4.80V	956.7	689.8	407.7	308.2	251.9	226.1	196.0	152.7	126.3	70.2
4.95V	939.6	675.6	399.2	302.5	247.0	221.7	192.2	149.8	123.8	68.1
5.10V	923.8	657.7	388.7	294.9	240.6	216.0	187.2	145.8	120.4	65.6
5.25V	889.2	632.6	373.8	283.6	231.4	207.7	180.0	140.2	115.8	62.5
5.40V	849.8	607.4	358.9	270.8	221.2	198.3	171.9	133.9	110.6	59.7
5.55V	809.8	579.9	342.7	256.9	209.6	188.0	162.9	126.9	104.8	55.2

All mentioned values are average values ( Tolerance ±2%)

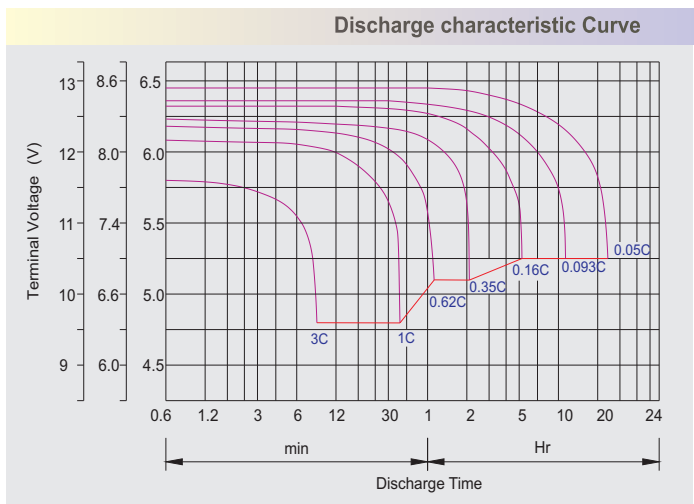
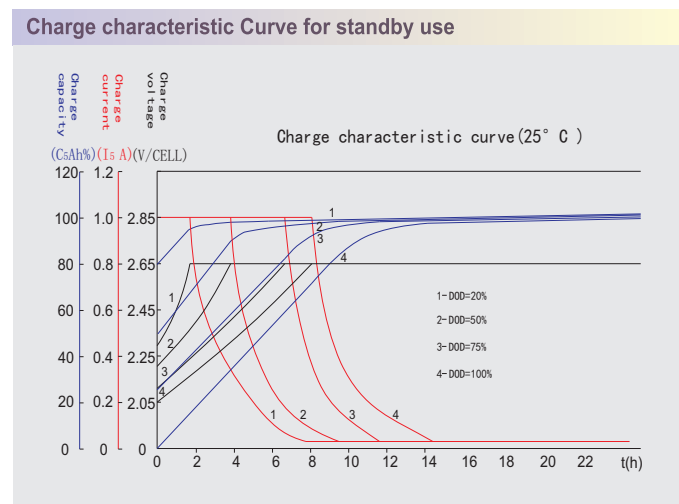
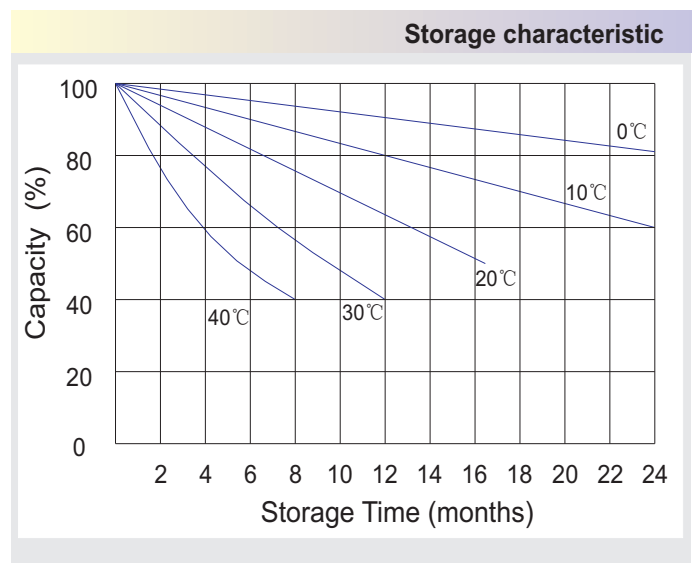
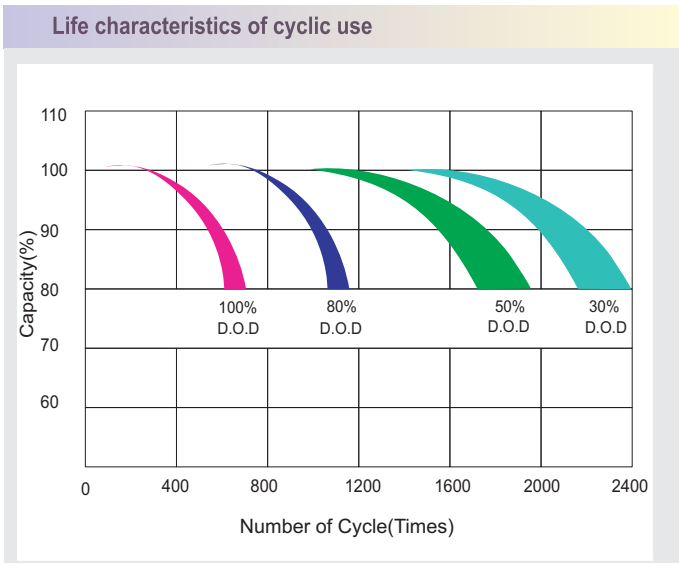

## Discharge Current VS. Discharge Voltage

Final D ischarge Voltage V /cell	1.75V	1.70V	1.60V
Discharge Current ( A )	( A ) ≤ 0.2C	0.2C < ( A ) < 1.0C	( A ) ≥ 1.0C

**Charge the batteries at least once every six months, if they are stored at 25°C.**

Charging Method(C=C<sub>s</sub>):

Constant Voltage	0.2Cx2h+2.65V/cellx12h,Max. Current 0.2C
Constant Current	0.14Cx6h+0.07Cx6h

## Maintenance & Cautions

<b>Cycle service</b>
※ Avoid battery over discharge, especially battery sereis connection use.
※ Charged with recommend voltage, ensure battery can be full recharged.
In general, recharge capacity should be 1.2-1.3 times discharge capacity.
※ Effect of temperature on cycle charge voltage: -4mV/°C/Cell.
※ There are a number of factors that will affect the length of cyclic service.
The most significant are depth of discharge, ambient temperature, discharge rate, and the manner in which the battery is recharged.
Generally specking, the most important factors is depth of discharge.